

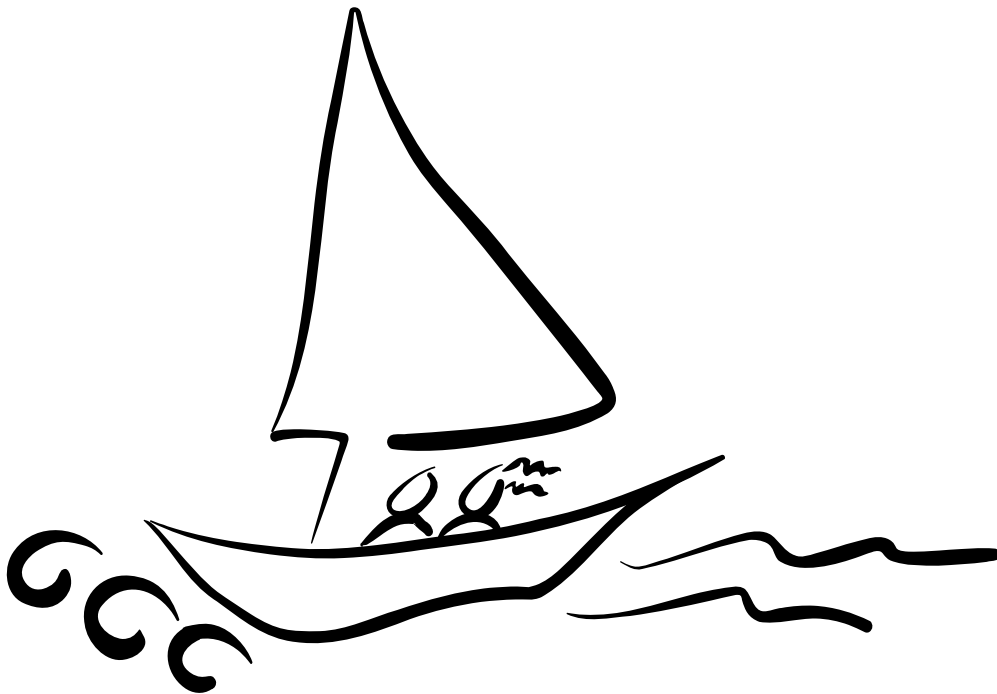

U.S. Army Corps
of Engineers
Jacksonville District

Lake Okeechobee and Okeechobee Waterway

Application for Shoreline Use



DEPARTMENT OF THE ARMY
U.S. Army Engineer District
South Florida Operations Office
525 Ridgelawn Road
Clewiston, Florida 33440

A Guide to Applicants

INTRODUCTION

The U.S. Army Corps of Engineers welcomes you to Lake Okeechobee and the Okeechobee Waterway. The Corps has been delegated authority by Congress to manage and regulate public use of the lake and waterway. As part of its management program, the Corps may issue permits to install minor private facilities.

The purpose of this application package is to furnish information on permit procedures for shoreline use as prescribed in the Lake Okeechobee and Okeechobee Waterway Shoreline Management Plan. Activities authorized by this Plan may take place in and along navigable waters of Lake Okeechobee and the Okeechobee Waterway between St. Lucie Lock and Dam in Martin County, Florida and W.P. Franklin Lock and Dam in Lee County, Florida. The purpose of the Plan is to provide policies and guidelines for the effective long-range management of the project's land, water, and shoreline. The illustrations included here are examples only; they illustrate construction methods that are acceptable, but not necessarily required. They include details that are required in an application, but alternate configurations may be approved as long as they meet the minimum requirements outlined in the shoreline management plan.

WHO MAY APPLY

Individuals who own property in fee title adjacent to public waters and share a common boundary line with the Corps or who have authorized access to the project shoreline allocated as limited development may apply for a Shoreline Use Permit/License/Consent to Easement. The type of items that may be permitted are based on the zoning of the shoreline adjacent to the shared common boundary line. First-time applicants for new facilities must meet on-site with a park ranger.

Individuals who have the consent or approval of the underlying fee-owner to access or perform modifications to lands that the Government owns an easement may also apply.

HOW TO APPLY

For information regarding a shoreline use permit/license/consent to easement on the Caloosahatchee River, contact the W.P. Franklin Visitor Center at (239) 694-2582. For information on a permit/license/consent to easement for the St. Lucie Canal, contact the St. Lucie Visitor Center at (772) 219-4575. For all other areas or for general information you may contact the South Florida Operations Office at (863) 983-8101.

A park ranger will meet with you to discuss shoreline management policies. You will be given an application packet to complete and return for review and approval. Final approval will not be given until the Operations Manager, South Florida Operations Office and the Chief of Real Estate Division review and issue the permit/license/consent to easement. Once approved a permit tag will be issued to the permittee. Permit tags must be displayed on the outside of the dock.

WHAT TO FILE

- Two copies of CESAJ 1196, Application and Permit/License/Consent-to-Easement for Shoreline Use **with original signatures**
- 5 Page Environmental Resource Permit (ERP)
- Location map
- Land modification drawings
- Construction standards for moorage facilities
- Moorage facility drawing
- Boat Ramp drawings
- Dredge plan drawings
- Electric Certification (if applicable)
- Check Payable to FAO, USAED, Jacksonville in the amount specified by the rate schedule.

WHERE TO FILE

South Florida Operations Office 525 Ridgelawn Road Clewiston, Florida 33440 (863) 983-8101	W.P. Franklin Visitor Center 1660 S. Franklin Lock Rd. Alva, Florida 33920 (239) 694-2582	St. Lucie Visitor Center 2170 SW Canal Street Stuart, Florida 34997 (772) 219-4575
---	--	---

WHAT MAY BE AUTHORIZED

- Shoreline Stabilization
- Dredging not to exceed 500 cubic yards
- Boat Ramps
- Aerial or Subaqueous Transmission Lines
- Single/Multi-Family Moorage Facilities
- Removal of Exotic Vegetation
- Planting Native Vegetation
- Underbrushing/Mowing

HOW TO MODIFY THE PERMIT

Modification to any part of a permit/license/consent to easement requires prior approval. A site review is generally required. Contact the South Florida Operations Office for additional information.

RENEWAL OF PERMITS

Permit renewals are normally processed within 30 days. Please keep your mailing address current.

RULES AND REGULATIONS

Regulations governing the use of Lake Okeechobee and the Okeechobee Waterway are established in the Code of Federal Regulations, Title 36, Chapter III, Part 327. Copies are available upon request.

NOTE

- All information required as part of the application must be submitted at the same time.
- Partial or incomplete packages will NOT be accepted.
- A permit must be issued before any work is begun

PROCESSING THE APPLICATION

It will take approximately 20 –25 business days to evaluate and process a land use application once it is received. Applications for boat mooring facilities and boat ramps may take as long as 120 days due to the requirement that they be coordinated with the U.S. Fish and Wildlife Service for impacts to manatees. Much of this time depends on accuracy and completeness of your application. Be sure to check all requirements prior to submitting application.

This package includes:

- Application and Permit/License/Consent to Easement for Shoreline Use, CESAJ Form 1196 (2 copies)
- Sample drawings
- Application requirements checklist
- Conditions of Permit/License/Consent to Easement for Shoreline Use
- Rate Schedule

NOTE: Do not perform any work before you receive written approval.

Application Requirements Checklist

1. Location Map: This map must be placed in the upper right hand corner of any one of the following drawings or submitted as a separate attachment.

- ❑ Show general location of activity; include name of waterway, highway, street names and/or numbers and the approximate distance to the nearest city or town.
- ❑ Show North arrow

2. Land Modification Drawings:

Plan or Overhead View

- ❑ Show specific area of activity (i.e. lot #, property lines, Corps of Engineers right-of-way line, survey monuments and numbers, shoreline, etc.)
- ❑ Show waterway and direction of flow.
- ❑ Show all existing land and shoreline characteristics (i.e. wetland vegetation, upland areas, etc.)
- ❑ Show extent of land modification activity and specific dimensions of activity. For bank sloping indicate length, width and grade.
- ❑ Show extent of bank revegetation and shoreline stabilization. Location and description of trees, grasses or shrubs to be planted, location of strip sod areas and rip rap if applicable.
- ❑ Show other activities on project land or water (i.e. location and description of water lines, electric lines, moorage facilities, etc.)

Cross Section or Side View

- ❑ Show cross section of activity. Include existing elevation of bank, approximate ordinary water line, grade of proposed activity, dimensions, elevation of slope (water ward) and Corps of Engineers right-of-way in relation to the activity.

3. Construction Standards for Moorage Facilities

- ❑ All wood materials are pressure treated with a preservative
- ❑ Metal materials (nails, brackets, support posts, roofing materials, etc.) are galvanized, stainless steel, patented enamel, anodized aluminum or a combination thereof
- ❑ Decking lumber is at least 2" x 4" in size
- ❑ Wood floor joists and framing for wood construction is not less than 2' x 6" in size
- ❑ Metal floor joist and frames are a minimum of 2" ID.
- ❑ Foundation posts are at least 6" round or 6" x 6" in size

- ❑ Walkways are at least 3 feet but not greater than 6 feet wide
- ❑ All handrails shall be 34 - 42 inches in height with an intermediate rail securely installed
- ❑ All wood materials are free from splits, decay, etc.
- ❑ Electrical service and equipment leading to or on private mooring facilities or other structures must not pose a safety hazard or conflict with other recreational use.
- ❑ All electrical installations must conform to the National Electric Code (NEC) and all state and local codes and regulations.
- ❑ All electrical service must be waterproof and include the installation of a ground fault circuit interrupter (GFCI).
- ❑ The facility must be equipped with quick-disconnect fittings mounted landward of the right-of-way boundary line. The quick-disconnect must be accessible at all times to Corps personnel, regardless of the owner's presence.
- ❑ Details of all electrical service hardware and locations must be illustrated on a diagram and provided with the application.
- ❑ All electrical installations must be certified in writing by a licensed, registered, or otherwise certified electrician. A copy of the electrical certification (license) must be provided to the operations project manager before a Shoreline Use Permit can be issued or renewed.
Renewal permits will not be issued until a licensed electrician has performed an electrical inspection, and documentation has been provided with the application for renewal.
- ❑ All electrical lines must be installed underground.

4. Moorage Facilities Drawings:

Plan or Overhead View:

- ❑ Show specific area of structure in relation to property lines, Corps of Engineers right-of-way, shoreline, waterway and show direction of waterway flow
- ❑ Show specific dimensions of structure. Single-family moorage facilities shall not exceed the minimum size required to moor the owner's boat(s) or 1,000 square feet (whichever is less).
- ❑ Show structures distance from property lines and Corps of Engineers right-of-way
- ❑ Show its distance from existing adjacent docks (single-family moorage facilities and other private structures shall be spaced no closer than 50 feet from structure to structure).

Cross Section or Side View:

- ❑ Show side view of structure and include specific dimensions, size of materials, ordinary waterline, shoreline, vegetation, etc.

5. Dredging Plan Drawings:

Plan or Overhead View:

- ❑ Show dredging activity in relation to moorage facility. Show specific dimensions of dredge area, shoreline, waterway and direction of flow.
- ❑ Indicate number of cubic yards of material to be removed, type of material, method of removal and handling and location of spoil disposal area.

Cross Section or Side View:

- ❑ Show cross section of activity to include dimensions of depth and width. Show dredging activity in relation to moorage facility. Indicate ordinary waterline and existing waterway bottom profile.

6. Boat Launching Ramp Drawings:

Plan or Overhead View:

- ❑ Show specific area of proposed activity (i.e. lot #, property lines, Corps of Engineers right-of-way line, survey monuments and numbers, shoreline, etc.)
- ❑ Show waterway and direction of flow.
- ❑ Show all existing land and shoreline characteristics (i.e. wetland vegetation, upland areas, etc.)
- ❑ Show extent of launching ramp and specific dimensions of activity by indicating length and width.
- ❑ Show other activities on project land or water (i.e. location and description of water lines, electric lines, moorage facilities, etc.)

Cross Section or Side View:

- ❑ Show cross section of launching ramp. Include existing elevation of bank, approximate ordinary water line, grade of proposed activity, dimensions, and Corps of Engineers right-of-way in relation to the proposed activity.
- ❑ Show cross section to include dimensions of depth and width. Indicate ordinary waterline and existing waterway bottom profile.

7. Application for Permit/License/Consent to Easement:

- ❑ Have you completed and included two copies of CESAJ Form 1196?
- ❑ If you are not the underlying fee owner, do you have permission from the fee owner?
- ❑ Are all pertinent maps and drawings included and completed according to sample drawings and checklist?
- ❑ Is location map specific enough to direct project personnel to the site?
- ❑ Is the appropriate fee enclosed? Checks and money orders must include full name, address, telephone number and drivers license number and made payable to FAO, USAED, Jacksonville.

Sample Moorage Facility Drawing

Overhead View

Caloosahatchee River

← Flow

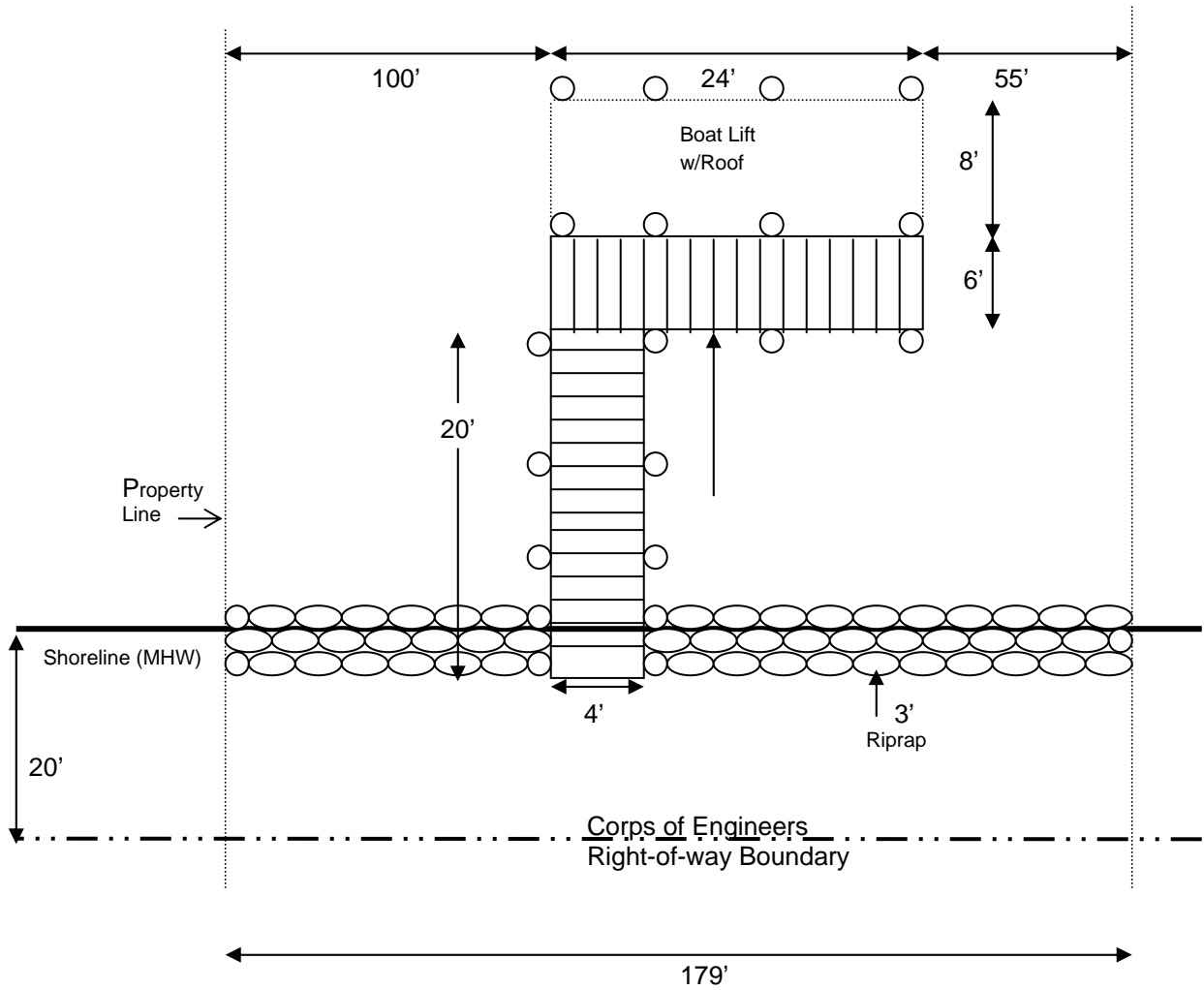

Sample Moorage Facility Electrical Drawing

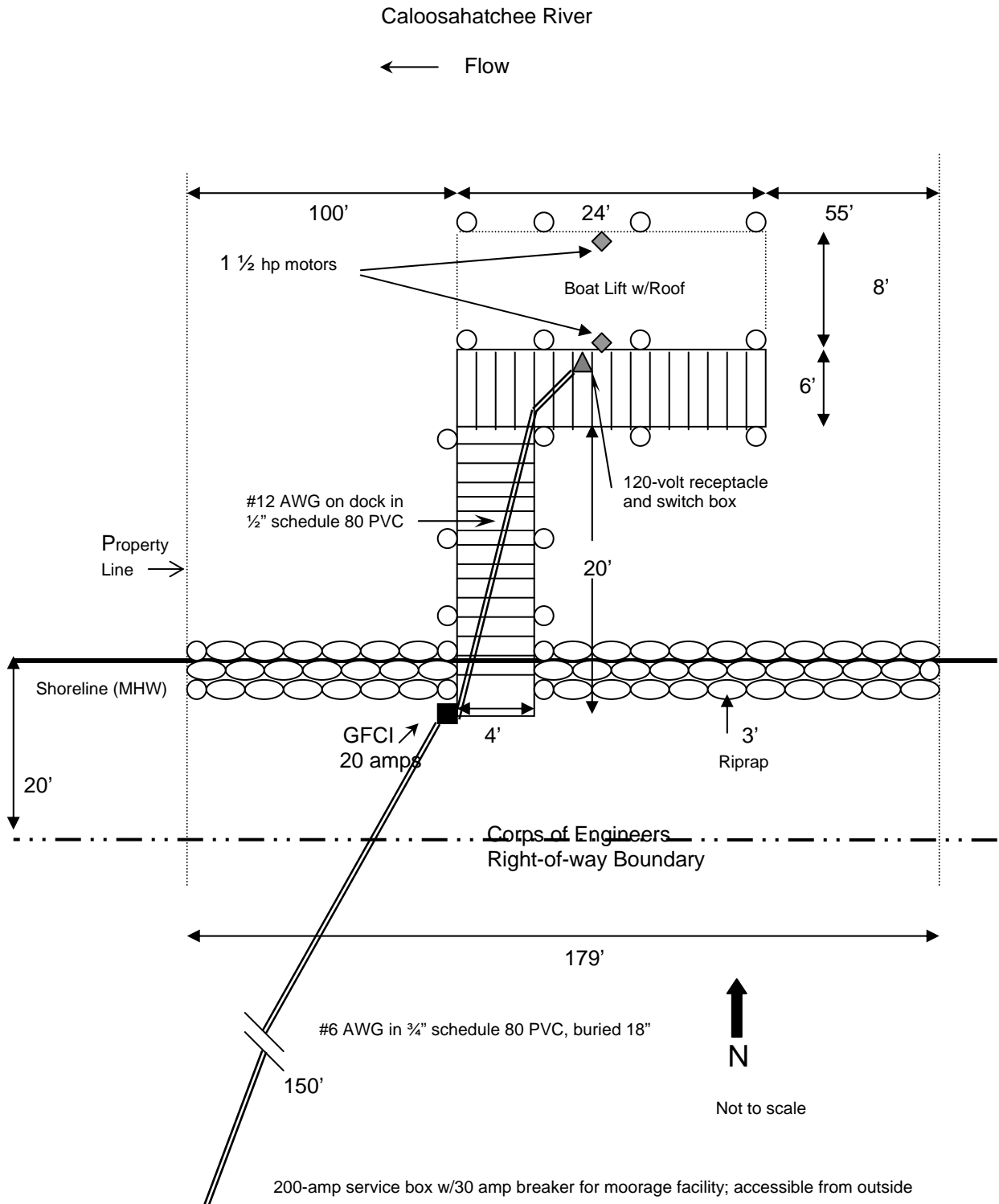

Sample Moorage Facility Drawing

Cross Section View

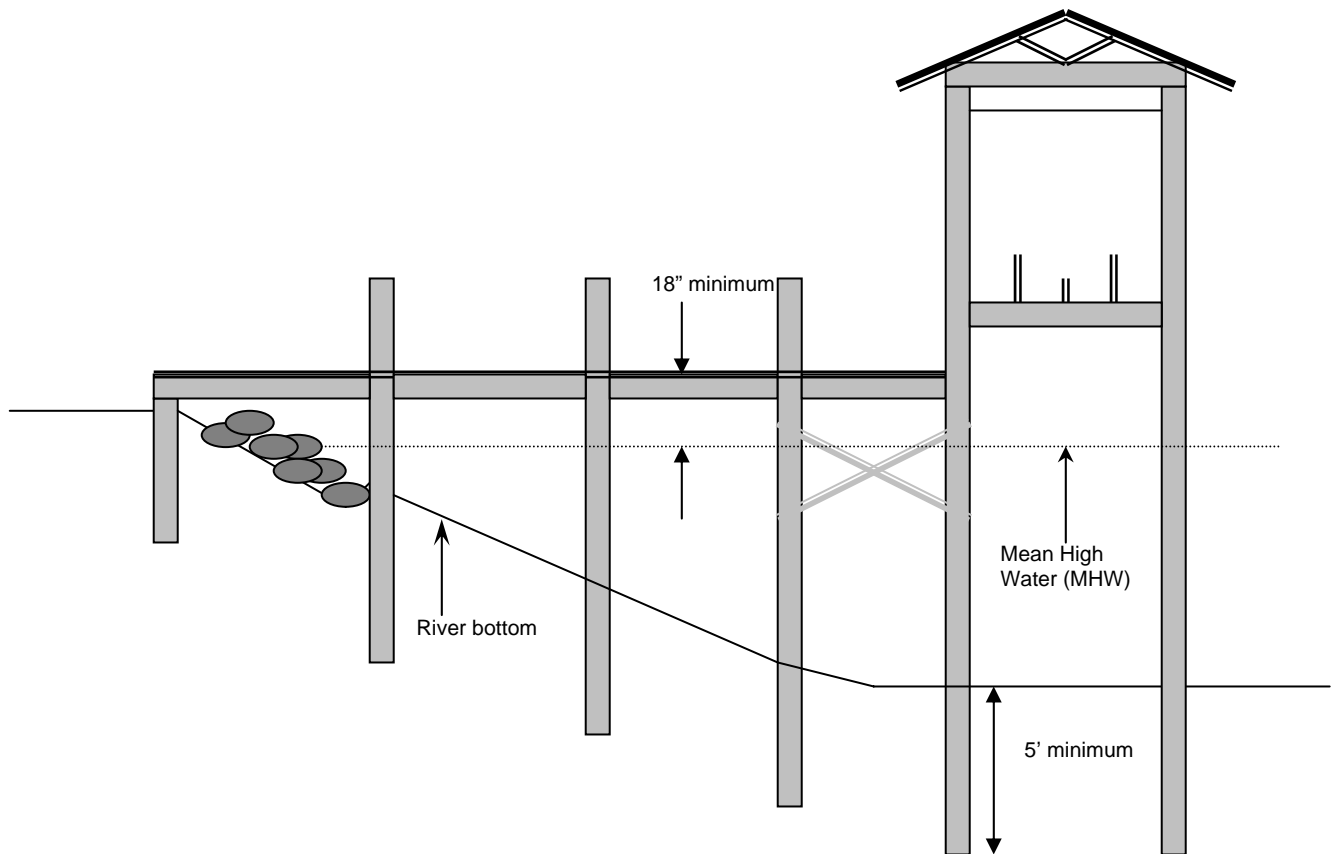

Sample Moorage Facility Drawing

Construction Detail

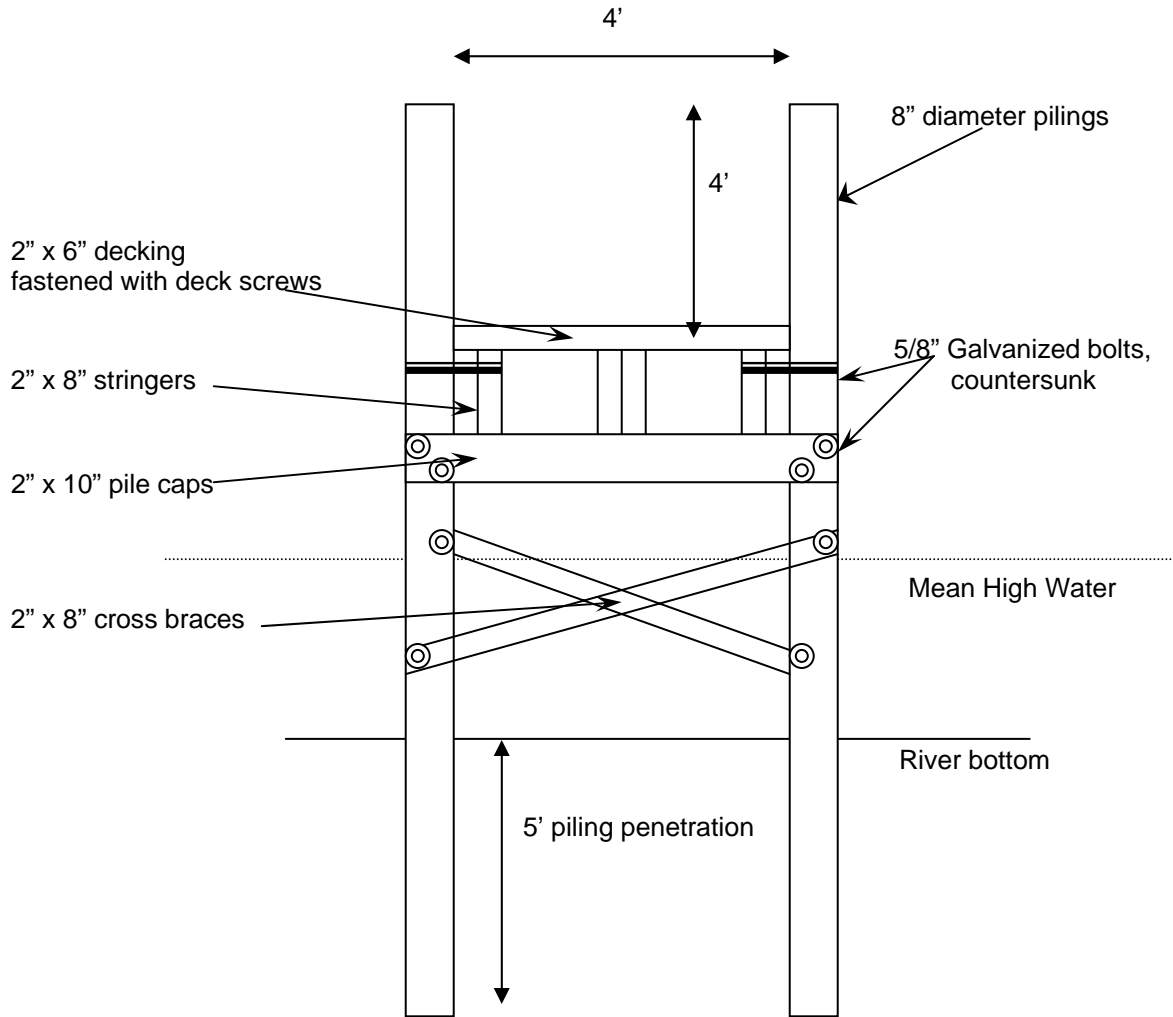

All wood is pressure treated, AWPB LP-2 minimum.
Pilings are pressure treated, 0.80 CCA

Sample Moorage Facility Drawing

Roof Side View

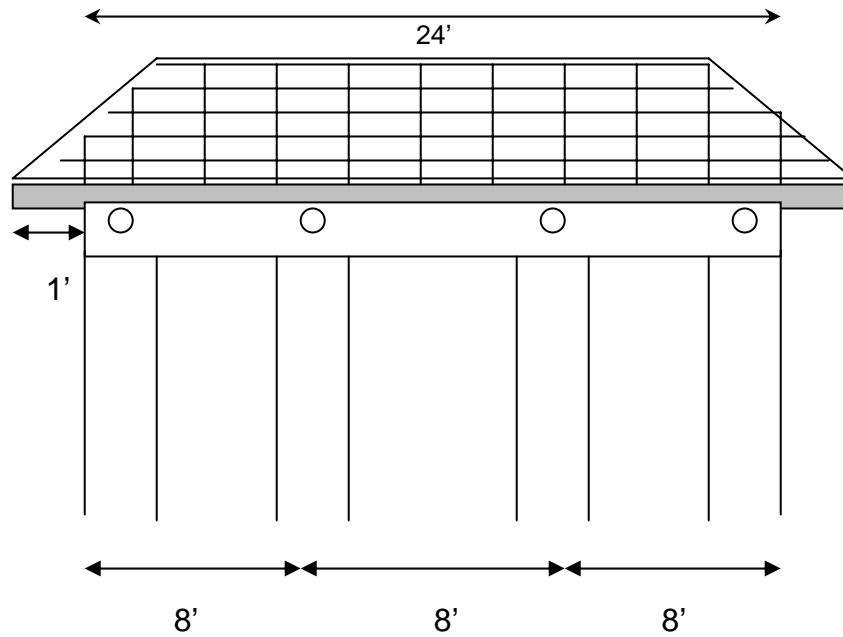

Roof End View

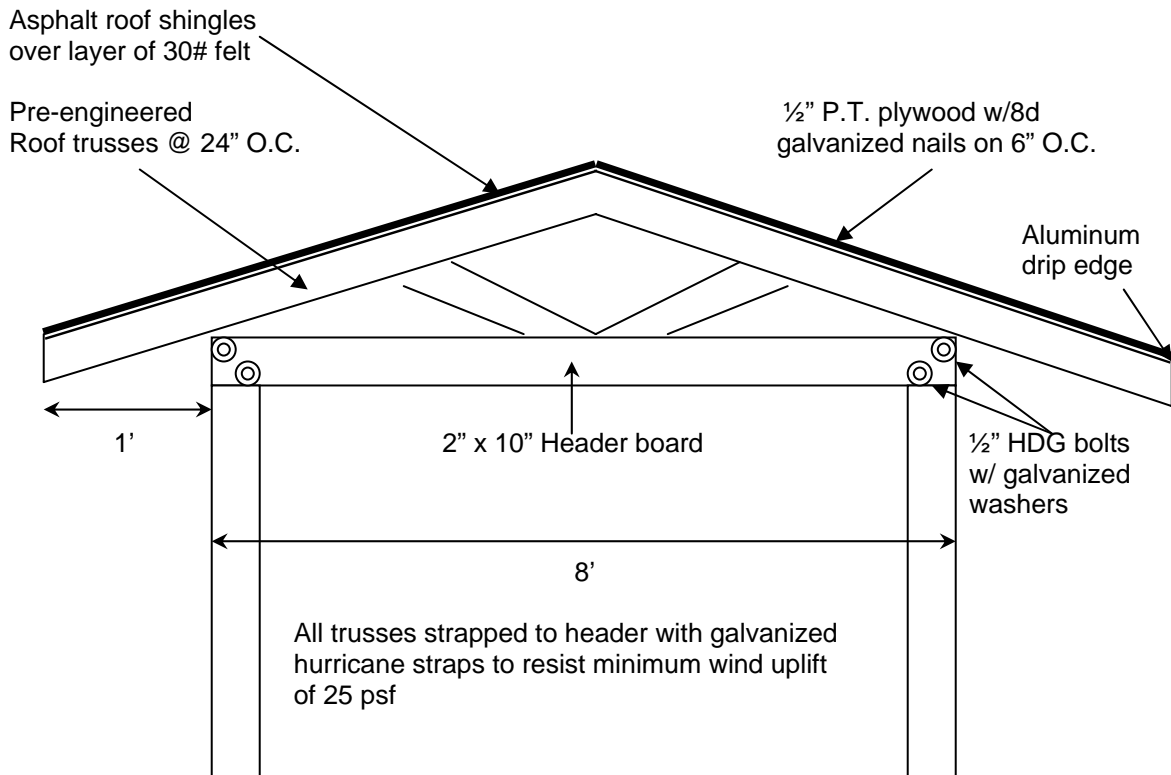

Sample Land Sloping Drawing

Overhead View

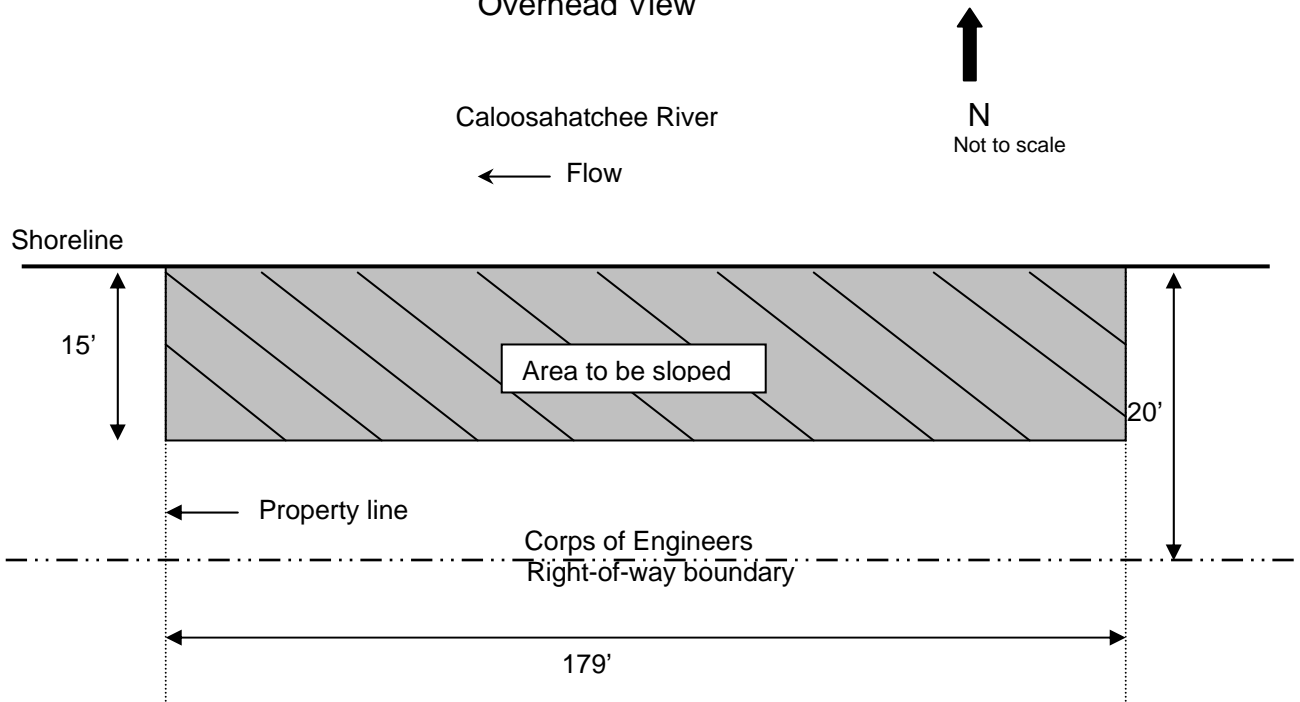

Cross Section View

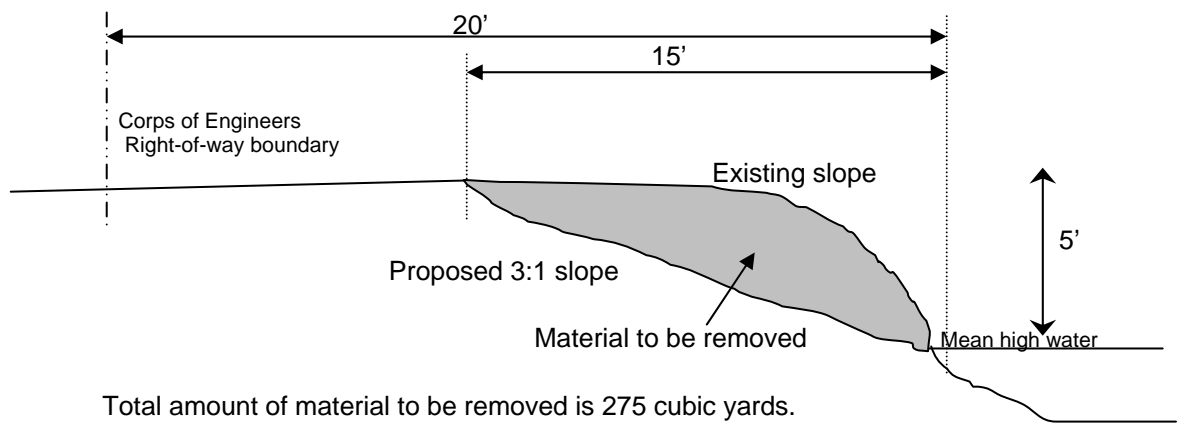

Total amount of material to be removed is 275 cubic yards.
Material to be placed on upland site off of Government property.

Sample Riprap Drawing

Cross Section View (key trench)

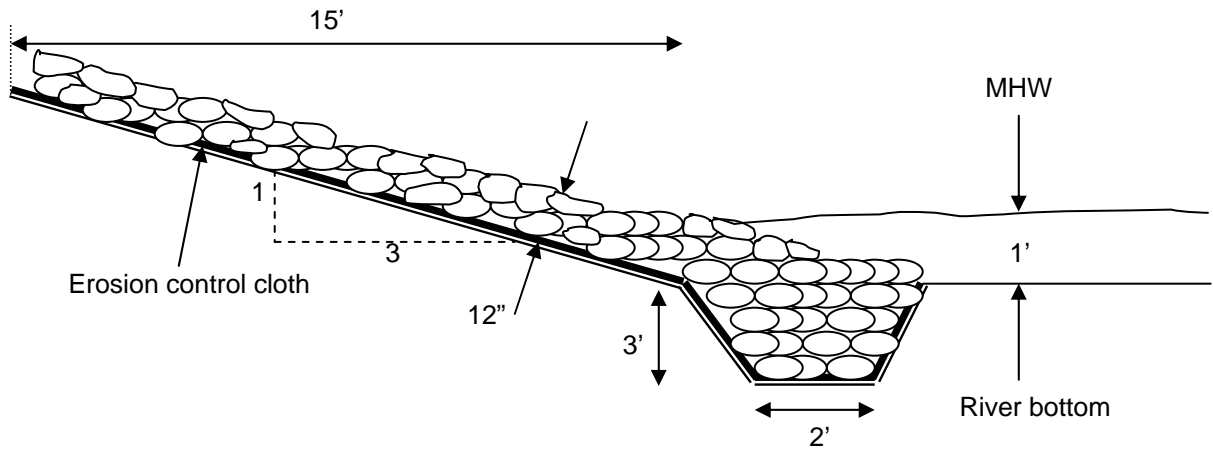

Longitudinal View (end trenches)

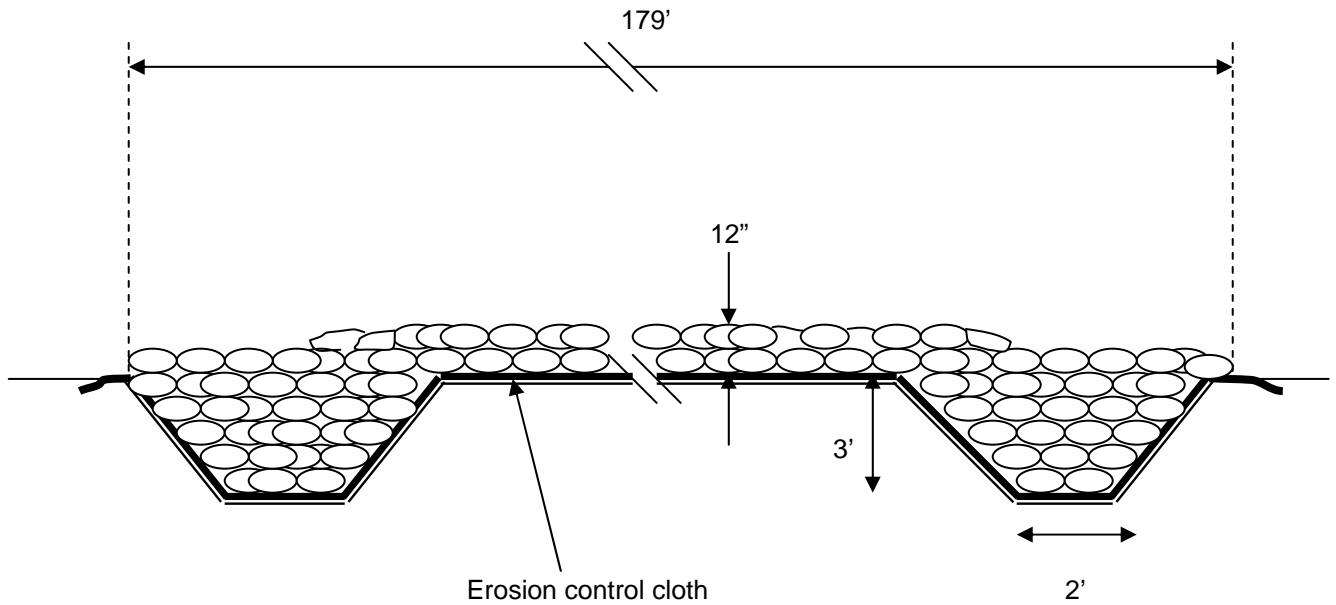

Riprap will be natural stone 20 – 200 pounds

Sample Boat Ramp Drawing

Overhead View

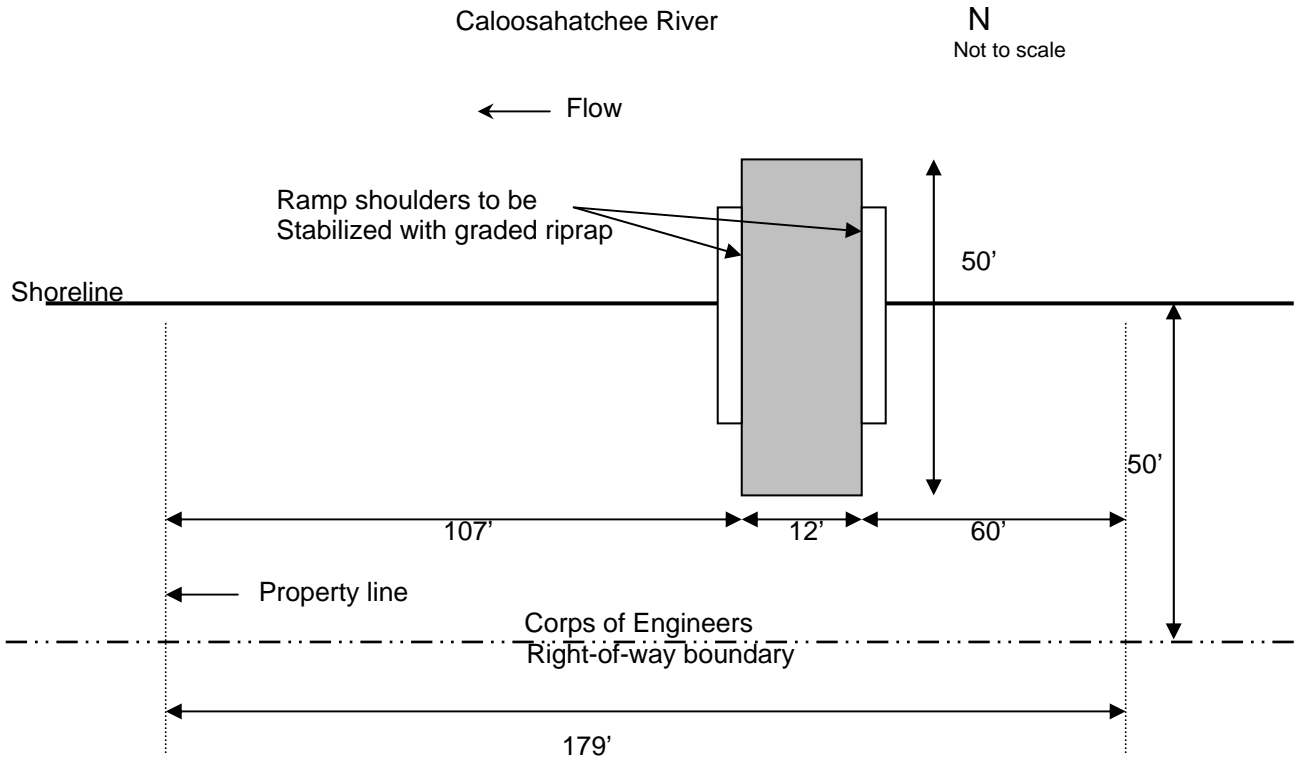

Cross Section View

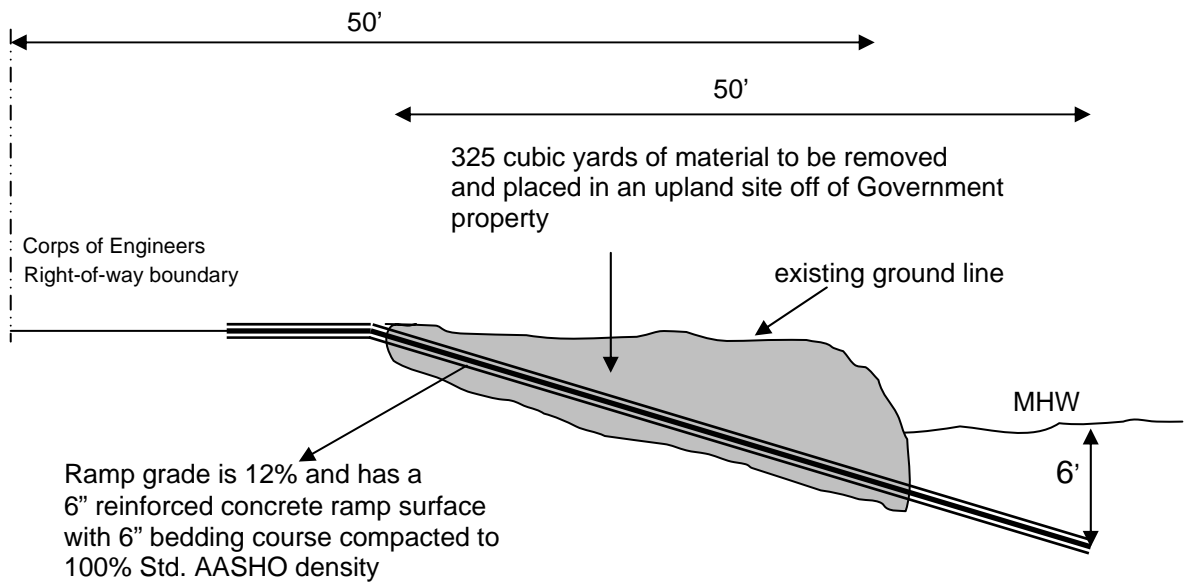

Sample Location Maps

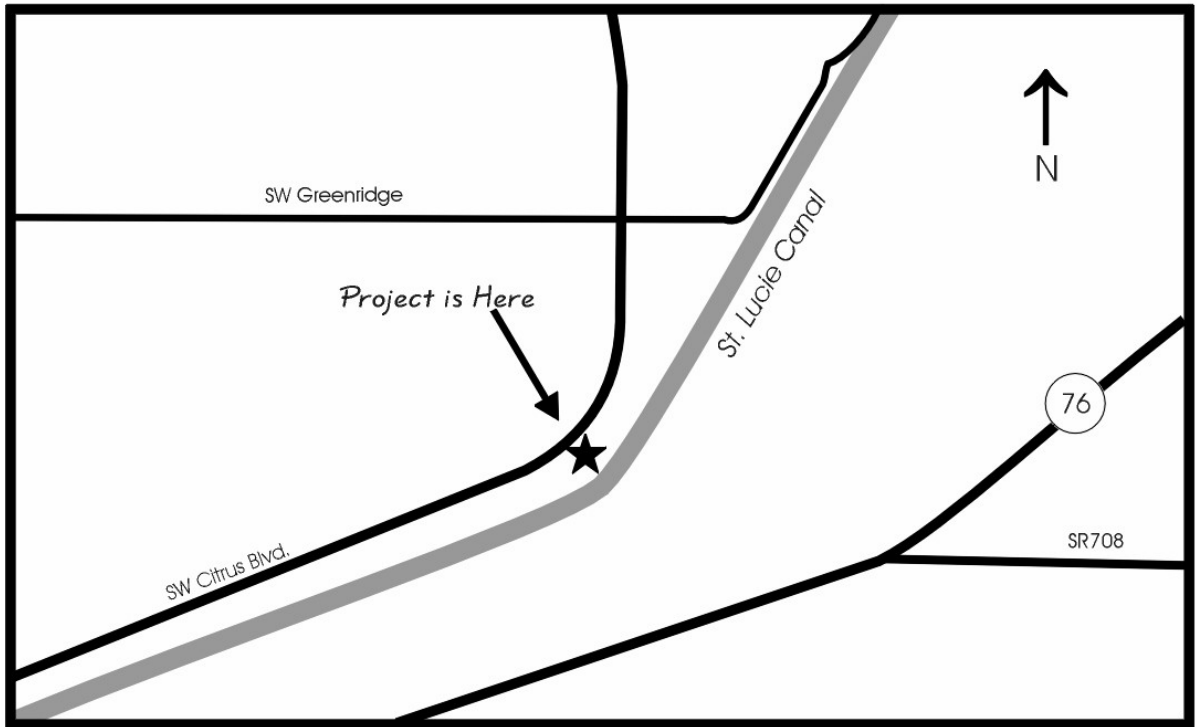
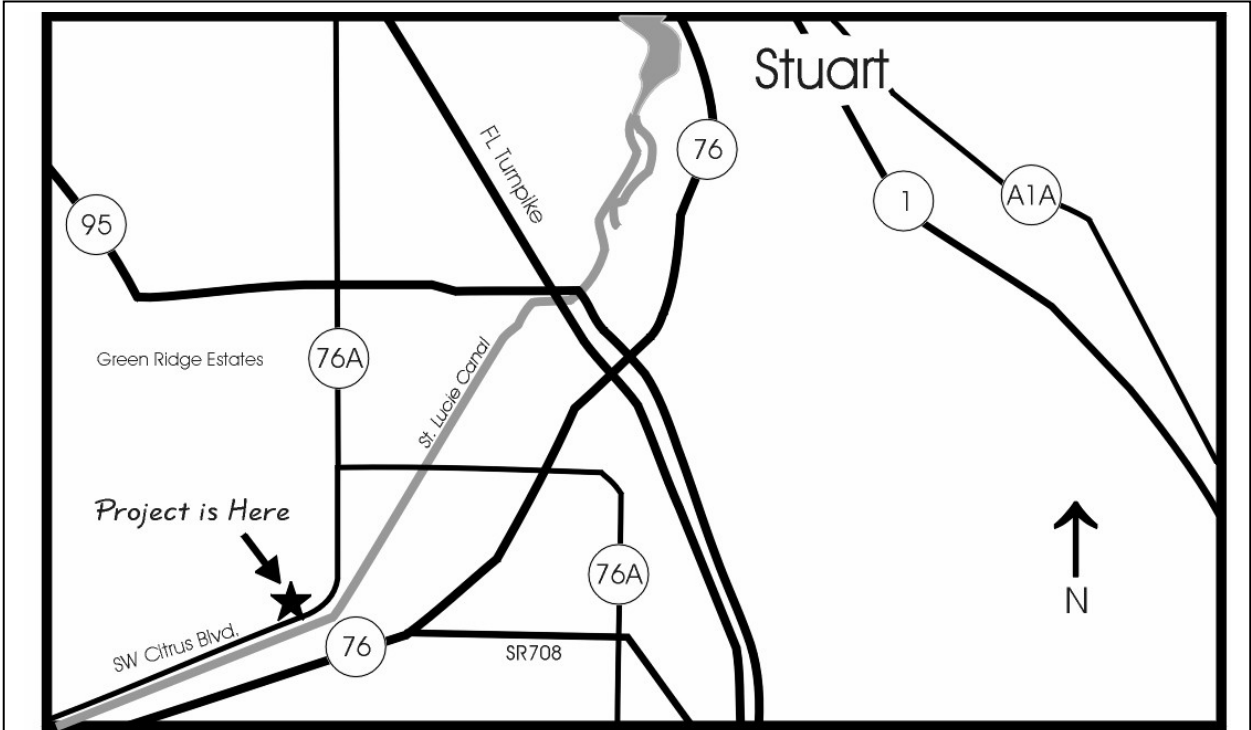

This project is located on the north side of the St. Lucie Canal, approximately 18 miles southwest of Stuart, Florida, off of SW Citrus Boulevard and Tangerine Court.

Sample Electrical Certification

Acme Electric
1234 Wire Nut Road
Stuart, Florida 34997
(561) 555-5555

November 20, 2002

Subject: Installation of electrical service to Mr. John Q. Public boat dock at 5678 SW Citrus, Blvd.
Stuart, Florida

Dear Park Ranger Ohms:

The electrical service to Mr. Publics dock will be installed in accordance with the current standards of the National Electric Code and all applicable state, county and local codes. All components are suitable for damp or wet locations and lines crossing the right-of-way will be placed underground. The service includes ground fault circuit protection and has a quick disconnect fitting/shutoff mounted landward of the Corps of engineers boundary line in a location accessible from the outside. If you have any questions please contact me. I have enclosed a copy of my current license.

Sincerely,

Richard P. Ampere

Richard P. Ampere
License # EC-000ABC

AC# 4138			STATE OF FLORIDA Department of Business and Professional Regulation ELECT CONTRACTORS LICENSING		
DATE 12/12/01	BATCH NUMBER 98732165	LICENSE NBR EC-000ABC			
The ELECTRICAL CONTRACTOR Named below HAS REGISTERED Under the provisions of Chapter 489, FS Expiration date: DECEMBER 11, 2003 (INDIVIDUAL MUST MEET ALL LOCAL COMPETENCY REQUIREMENTS PRIOR TO CONTRACTING IN ANY AREA)					
Richard P. Ampere 1234 Wire Nut Road Stuart, Florida 34997					
Charlie Crist GOVERNOR			DISPLAY AS REQUIRED BY LAW		

CONDITIONS OF PERMIT/LICENSE/CONSENT TO EASEMENT
FOR SHORELINE USE

1. The Grantee shall pay, to the United States of America, (hereinafter referred to as the "Government"), prior to issuance of outgrant, compensation in accordance with the fee schedule attached hereto as Exhibit "B". Checks should be made payable to FAO, USAED, Jacksonville.
2. The exercise of privileges hereby granted shall be without cost or expense to the Government, under the general supervision and approval of the officers executing this instrument or duly authorized representative (hereinafter the Operations Manager), subject to such regulations as may be prescribed by him from time to time, and is subject to the Government's navigation servitude; Title 33, Code of Federal Regulations Part 325, and to all applicable Federal, State and local laws and regulations.
3. The Government has a right-of-way easement over the above-numbered tract of land, which easement, by its terms, reserves to the Government, in perpetuity, the right to use said easement for the construction, improvement, and maintenance of the Okeechobee Waterway, Florida.
4. It is understood that this instrument is effective only insofar as the property rights of the Government in the land to be occupied are concerned, and that it does not relieve the Grantee from the necessity of obtaining grants from the owners of the fee and/or other interests, therein, nor does it eliminate the requirement that the grantee obtain State or local approval required by law for the activity authorized herein. That any proposed improvements or use authorized herein shall not be commenced until appropriate rights have been obtained by the Grantee from the record owners and encumbrances of the fee title to the lands involved, or until the Grantee has obtained all Federal, State, or local permits required by law.
5. This instrument does not convey any property rights, either in real estate or material, or any exclusive privileges, and it does not authorize any injury to property or invasion of rights or any infringement of Federal, State or local laws or regulations.
6. Structures are subject to periodic inspections by Corps personnel. If an inspection reveals conditions that make the facility unsafe in any way, or conditions that deviate from the approved plans, the owner, upon receipt of notification will correct such conditions immediately. The Government shall in no case be liable for failure to supervise or inspect the improvements or use authorized herein. No deviations or changes from approved plans will be permitted without prior written approval from said officer. That any improvements or use not specifically authorized or identified herein shall constitute a violation of this instrument which may result in a revocation of

this instrument and in the institution of such legal proceeding as the Government may consider appropriate, whether or not this instrument has been revoked or modified.

7. Any property of the Government damaged or destroyed by exercising the privileges herein granted shall be promptly repaired or replaced by the Grantee to the satisfaction of the Operations Manager, or in lieu of such repair or replacement the Grantee shall, if so required by the Operations Manager, pay to the Government, money in an amount sufficient to compensate for the loss sustained by the Government by reason of damage to or destruction of Government property.
8. The Grantee agrees that the Government shall not be responsible for damages to the property or injuries to the persons which may arise from or be incident to the exercise of the privileges herein granted, or for damages to the property or for injuries to the person of the Grantee, or the persons of Grantee's officers, agents, servants, employees or others who may be on the premises at the invitation of the Grantee or at the invitation of one of them, and the Grantee shall hold the Government harmless from any and all claims, causes of action, suits at law or from any liability of any nature. The Government shall in no case be liable for any damage or injury to the improvements authorized herein which may be caused by the Government for the improvement of navigation or arising from Governmental activity on or in the vicinity of the property.
9. That the Grantee hereby recognizes that structures granted within Federal navigation waterways are subject to damage by wavewash from passing vessels. The issuance of this outgrant does not relieve the Grantee from taking all proper steps to ensure the integrity of the structure granted herein and the safety of boats moored thereto from damage by wavewash, and the Grantee shall not hold the Government liable for any such damage nor restrict in any way the full use of the Federal Waterway by the general public by the placement of unauthorized "no wake" signs and/or buoys. Speed zones will not be authorized to protect private property.
10. Should the grantee cease to operate and/or maintain the approved facility, or upon the relinquishment, termination, expiration, revocation, forfeiture, or annulment of this instrument, the Grantee shall remove his/her facility within 30 days, at his/her expense, and restore the water and land area to its former condition. If the Grantee fails to remove and restore the water premises to the satisfaction of the Operations Manager, the Operations Manager may do so by contract or otherwise and recover the cost thereof from the Grantee, and no claim for damages against the Government, or its officer or agents, shall be created by or made on account of such removal or restoration.

11. No attempt shall be made by the Grantee to forbid the full and free use by the public of all navigable waters and/or Government-owned shoreline, at or adjacent to the approved facility.
12. Floats and flotation material for all docks shall be fabricated of materials manufactured for marine use. The float and its flotation material shall be 100% warranted for a minimum of 8 years against sinking, becoming waterlogged, and cracking, peeling, fragmenting or losing beads. All floats shall resist puncture and penetration and shall not be subject to damage by animals under normal conditions for the area. All floats and the flotation material used in them shall be fire resistant. The use of new or recycled plastic or metal drums or non-compartmentalized air containers for encasement or floats is prohibited.
13. No improvement authorized is to be used for human habitation. Household furnishings are not permitted on boat piers, boathouses, or other structures. No houseboat, cabin cruiser or other vessel shall be used for human habitation at any mooring point.
14. No charge may be made for use of the facility, nor shall commercial activities be conducted thereon.
15. The outgrant tag provided for structures shall be posted on the facility or on the land areas covered by the instrument so that it can be visually checked with ease in accordance with instructions of the Operations Manager.
16. No vegetation other than that prescribed may be damaged, destroyed or removed. No vegetation of any kind will be planted other than that specifically prescribed. No change in landform such as grading, excavation or filling may be done, other than that specifically prescribed.
17. The Grantee agrees that he will complete construction within 1 year of the instrument's issue date. The instrument shall become null and void if construction is not completed within that period. Further, the Grantee agrees that he/she will operate and maintain the facility in a manner so as to minimize any adverse impact on fish and wildlife habitat, natural environmental values, and in a manner so as to minimize the degradation of water quality.
18. The Grantee agrees that if subsequent operations by the Government require an alteration in the location of the facility or, if in the opinion of the said officer, the facility shall cause unreasonable obstruction to navigation or that the public interest requires, the grantee shall, upon written notice from the said officer, remove, alter, or relocate the facility, without expense to the Government, and no claim for damages shall be made against the Government on account of such alterations, removal or relocation.

19. General permit proposals and plans must be reviewed and approved by the Operations Manager. The Operations Manager will administer General Permits under the guidelines of Section 4, 1944 Flood Control Act, as amended, PL 87-874 (16 USC 460.d) and changes for shoreline management as specified in Title 36 CFR, Part 327.30, Shoreline Management Plan.
20. In issuing authorizations under these procedures, the Government has relied on the information and data that the Grantee has provided in connection with his/her application. If, subsequent to the issuance of an authorization under the Shoreline Management Plan, such information and data prove to be materially false, incomplete or inaccurate, the authorization may be modified, suspended or revoked, in whole or in part and/or the Government may, in addition, institute appropriate legal proceedings.
21. Activities which are not specified in the Shoreline Management Plan or General Permits or which exceed the limitations of these outgrant conditions will require individual Department of the Army authorization from the Corps of Engineers before work can commence. The District Commander may also require authorization under general or individual permits for a specific project that might be contrary to the public interest.
22. That the Grantee shall not remove or disturb, or cause or permit to be removed or disturbed, any historical, archaeological, architectural, or other cultural artifacts, relics, vestiges, remains, or objects of antiquity. In the event such items are discovered on the premises, the Grantee shall immediately notify the Operations Manager, and the site and the material shall be protected by the Grantee from further disturbance until a professional examination of them can be made or until clearance to proceed is authorized by the Operations Manager.
23. This instrument is non-transferable. Upon the sale or other transfer of the facility or the death of the permittee and his/her legal spouse, this permit is null and void.
24. If the ownership of a facility is sold or transferred, the permittee or new owner will notify the operations manager of the action prior to finalization. The new owner must apply for a Shoreline Use Permit/License/Consent to Easement within 30 days or remove the facility and restore the area within 90 days from the date of ownership transfer.
25. If the ownership of a facility is sold or transferred, the permittee or new owner will notify the operations manager of the action prior to finalization. The new owner must apply for a Shoreline Use Permit/License/Consent to

Easement within 30 days or remove the facility and restore the area within 90 days from the date of ownership transfer.

26. By 30 days written notice, mailed to the Grantee by certified mail, the Operations Manager may revoke this instrument whenever he determines that the public interest necessitates such revocation or when he determines that the grantee has failed to comply with the conditions of this instrument. The revocation notice shall specify the reasons for such action. If within the 30-day period the Grantee requests a hearing in writing to the District Commander through the Operations Manager, the District Commander shall grant such hearing at the earliest opportunity. In no event shall the hearing date be more than 60 days from the date of the hearing request. Following the hearing, a written decision will be rendered and a copy mailed to the Grantee by certified letter.
27. Notwithstanding condition 25 above, if in the opinion of the District Commander, circumstances dictate, the District Commander may summarily revoke this instrument.
28. The Operations Manager or his/her authorized representative shall be allowed to cross the Grantees property, as necessary, to inspect facilities and/or activities under permit.
29. When vegetation modification is allowed, the Grantee will delineate the Government easement boundary in a clear but not unobtrusive manner approved by the Operations Manager in accordance with the Lake Okeechobee and Okeechobee Waterway Shoreline Management Plan.
30. Prior to the execution of this instrument, Condition #'s _____ were deleted.

This instrument is not subject to Title 10, United States Code Section 2662, as amended.

South Atlantic Division Fee Schedule
 FOR CONSOLIDATED PERMITS
 COVERING SHORELINE FACILITIES/ACTIVITIES
 Effective 1 January 2006

ADMINISTRATIVE FEES for docks & other facilities (5-Year Term)

New Permit (or new owner of existing facility)	\$400
Re-issue Permit (to same owner of existing facility.)	\$175
Permit Modification ¹ (additions/changes to existing facility)	\$90

¹ Modifications may not be for a five year term.

PLUS +

FAIR MARKET VALUE FEE, if applicable (5-Year Term)

	<u>Fee Estate</u>	<u>Easement Estate</u>
Utility right-of-way (each utility)	\$35.00	No charge
Boat launching ramp	\$67.00	No charge
Clearing of underbrush and/or mowing	\$10.00	No charge
Erosion Control	No charge	No charge

Notes:

1. Fees will be prorated when the instrument is issued for terms shorter than 5 years. However, a minimum of \$20.00 will be imposed for all uses except erosion control.

2. Fees for approved privileges not listed above will be commensurate with the privilege granted.



**US Army Corps
Of Engineers**
Jacksonville District

Application for Permit/License/Consent to Easement for Shoreline Use (ER 1130-2-406)

Print or type the information requested below. Submit two signed copies with two complete sets of plans and specifications to the **Operations Manager**. (READ PRIVACY ACT STATEMENT REVERSE SIDE)

Name of Applicant _____ **Date** _____

Address _____ **Telephone** _____

City _____ **State** _____ **Zip Code** _____

Description of Shoreline Activity: Please add the appropriate information or circle the correct response.
 Moorage Facility in Square Feet: _____, Boat Lift (Yes/No), Roof (Yes/No),
 Utility Right-Of-Way: Electric (Yes/No), Water (Yes/No), Boat Ramp (Yes/No), Pump (Yes/No)
 Underbrushing/Mowing (Yes/No), Removal of Exotic Vegetation (Yes/No), Planting Native Vegetation
 (Yes/No), Dredging in Cubic yards _____
 Linear Feet of Shoreline Modifications: Riprap _____, Sloping _____ at a slope of ____:____,
 Section _____ Township _____ Range _____ Government Tract# _____
 County: _____ State _____ Boat Registration# _____
 GPS Coordinates: _____
 Closest Survey Monument Station # _____

The following person will be available on short-notice call and will be responsible for providing any needed surveillance of the structure in my absence. **NOTE THIS PERSON MUST BE DIFFERENT THAN THE APPLICANT NAMED ABOVE**

Name _____ **Telephone (____)** _____

Address _____

City _____ **State** _____ **Zip Code** _____

I understand the conditions of this Permit/License/Consent to Easement which are attached hereto as Exhibit "A" and hereby accept this instrument together with all conditions thereof, this _____ day of _____, 20____.

Grantee

This block to be completed by the **Operations Manager**

Special Permit/License/Consent to Easement Conditions:
 PLEASE WEAR YOUR LIFE JACKET WHILE BOATING

Permit/License/Consent to Easement Number _____

Date Issued _____ **Expiration Date** _____

The Secretary of the Army hereby grants to the applicant named above a Permit/License/Consent to Easement for the period specified above, to construct, use and maintain the items specified and described above and more particularly identified on Exhibit "B" at location shown in red on Exhibit "C" attached hereto and made a part hereof.

IN WITNESS WHEREOF, I have hereunto set my hand by authority of the Secretary of the Army

this _____ day of _____, 20____

Approved as to Use of Project Easement Lands

X _____
Operations Manager

X _____

PRIVACY ACT STATEMENT

AUTHORITY

Section 4, 1944 Flood Control Act as amended, PL 87-874.

PURPOSES

To provide information for contact of responsible party available on short notice in case of emergency. Needed for description of facility to assure conditions of outgrant requirement are met.

USES

These applications are used in considering the issuance of permit, license, and consent to easement for private exclusive use of Corps project lands and waters. This information is collected and maintained at project offices and is used as a basis for issuing outgrants and to provide auditing information for program with financial involvement.

EFFECTS OF NONDISCLOSURE

Disclosure of information is voluntary. Failure to provide information will preclude issuance of the permit/license/consent to easement.

Special Note from the Operations Manager:

Thank you for the submission of a completed shoreline application. Normal processing time of an application varies depending on the facility and activity but is generally three to five weeks. Please contact the Park Ranger that supplied the application for a status or to answer any questions. Remember, that no modifications may be completed without prior approval from the Corps of Engineers and that your Permit/License/Consent to Easement will expire in five years and must be renewed prior to the expiration date. As always, please be safe while recreating or working around the water and always wear your life jacket while boating.



**US Army Corps
Of Engineers**
Jacksonville District

Application for Permit/License/Consent to Easement for Shoreline Use (ER 1130-2-406)

Print or type the information requested below. Submit two signed copies with two complete sets of plans and specifications to the **Operations Manager**. (READ PRIVACY ACT STATEMENT REVERSE SIDE)

Name of Applicant _____ **Date** _____

Address _____ **Telephone** _____

City _____ **State** _____ **Zip Code** _____

Description of Shoreline Activity: Please add the appropriate information or circle the correct response.
 Moorage Facility in Square Feet: _____, Boat Lift (Yes/No), Roof (Yes/No),
 Utility Right-Of-Way: Electric (Yes/No), Water (Yes/No), Boat Ramp (Yes/No), Pump (Yes/No)
 Underbrushing/Mowing (Yes/No), Removal of Exotic Vegetation (Yes/No), Planting Native Vegetation
 (Yes/No), Dredging in Cubic yards _____
 Linear Feet of Shoreline Modifications: Riprap _____, Sloping _____ at a slope of ____:____,
 Section _____ Township _____ Range _____ Government Tract# _____
 County: _____ State _____ Boat Registration# _____
 GPS Coordinates: _____
 Closest Survey Monument Station # _____

The following person will be available on short-notice call and will be responsible for providing any needed surveillance of the structure in my absence. **NOTE THIS PERSON MUST BE DIFFERENT THAN THE APPLICANT NAMED ABOVE**

Name _____ **Telephone (____)** _____

Address _____

City _____ **State** _____ **Zip Code** _____

I understand the conditions of this Permit/License/Consent to Easement which are attached hereto as Exhibit "A" and hereby accept this instrument together with all conditions thereof, this _____ day of _____, 20____.

Grantee

This block to be completed by the **Operations Manager**

Special Permit/License/Consent to Easement Conditions:
 PLEASE WEAR YOUR LIFE JACKET WHILE BOATING

Permit/License/Consent to Easement Number _____

Date Issued _____ **Expiration Date** _____

The Secretary of the Army hereby grants to the applicant named above a Permit/License/Consent to Easement for the period specified above, to construct, use and maintain the items specified and described above and more particularly identified on Exhibit "B" at location shown in red on Exhibit "C" attached hereto and made a part hereof.

IN WITNESS WHEREOF, I have hereunto set my hand by authority of the Secretary of the Army

this _____ day of _____, 20____

Approved as to Use of Project Easement Lands

X _____
Operations Manager

X _____

PRIVACY ACT STATEMENT

AUTHORITY

Section 4, 1944 Flood Control Act as amended, PL 87-874.

PURPOSES

To provide information for contact of responsible party available on short notice in case of emergency. Needed for description of facility to assure conditions of outgrant requirement are met.

USES

These applications are used in considering the issuance of permit, license, and consent to easement for private exclusive use of Corps project lands and waters. This information is collected and maintained at project offices and is used as a basis for issuing outgrants and to provide auditing information for program with financial involvement.

EFFECTS OF NONDISCLOSURE

Disclosure of information is voluntary. Failure to provide information will preclude issuance of the permit/license/consent to easement.

Special Note from the Operations Manager:

Thank you for the submission of a completed shoreline application. Normal processing time of an application varies depending on the facility and activity but is generally three to five weeks. Please contact the Park Ranger that supplied the application for a status or to answer any questions. Remember, that no modifications may be completed without prior approval from the Corps of Engineers and that your Permit/License/Consent to Easement will expire in five years and must be renewed prior to the expiration date. As always, please be safe while recreating or working around the water and always wear your life jacket while boating.



**US Army Corps
Of Engineers**
Jacksonville District

Application for Permit/License/Consent to Easement for Shoreline Use (ER 1130-2-406)

Print or type the information requested below. Submit two signed copies with two complete sets of plans and specifications to the **Operations Manager**. (READ PRIVACY ACT STATEMENT REVERSE SIDE)

Name of Applicant John Q. Public Date 11/1/06
 Address 1234 Boat Dock Lane Telephone (555) 321-4567
 City Marina State FL Zip Code 98765

Description of Shoreline Activity: Please add the appropriate information or circle the correct response.

Moorage Facility in Square Feet: 425, Boat Lift (**Yes**/No), Roof (Yes/**No**),
 Utility Right-Of-Way: Electric (**Yes**/No), Water (Yes/**No**), Boat Ramp (Yes/**No**), Pump (Yes/**No**)
 Underbrushing/Mowing (**Yes**/No), Removal of Exotic Vegetation (Yes/**No**), Planting Native Vegetation (**Yes**/No),
 Dredging in Cubic yards N/A
 Linear Feet of Shoreline Modifications: Riprap 140, Sloping 140 at a slope of 4 : 1,
 Section 22 Township 43S Range 27E Government Tract# 221
 County Hendry State FL Boat Registration# FL 6630 BD
 GPS Coordinates: N26 45 26.1, W081 55 05.4
 Closest Survey Monument Station # S1313 +13

The following person will be available on short-notice call and will be responsible for providing any needed surveillance of the structure in my absence:

Name Jane Doe Telephone (555) 321-7654
 Address 1248 Boat Dock Lane
 City Marina State FL Zip Code 98765

I understand the conditions of this Permit/License/Consent to Easement which are attached hereto as Exhibit "A" and hereby accept this instrument together with all conditions thereof, this _____ day of _____, 20____, X

 Grantee

This block to be completed by the **Operations Manager**

Special Permit/License/Consent to Easement Conditions:

PLEASE WEAR YOUR LIFE JACKET WHILE BOATING

Permit/License/Consent to Easement Number _____
 Date Issued _____ Expiration Date _____

The Secretary of the Army hereby grants to the applicant named above a Permit/License/Consent to Easement for the period specified above, to construct, use and maintain the items specified and described above and more particularly identified on Exhibit "B" at location shown in red on Exhibit "C" attached hereto and made a part hereof.

IN WITNESS WHEREOF, I have hereunto set my hand by authority of the Secretary of the Army
 this _____ day of _____, 20____
 _____ Approved as to Use of Project Easement Lands

X _____ X _____
 Operations Manager

PRIVACY ACT STATEMENT

AUTHORITY

Section 4, 1944 Flood Control Act as amended, PL 87-874.

PURPOSES

To provide information for contact of responsible party available on short notice in case of emergency. Needed for description of facility to assure conditions of outgrant requirement are met.

USES

These applications are used in considering the issuance of permit, license, and consent to easement for private exclusive use of Corps project lands and waters. This information is collected and maintained at project offices and is used as a basis for issuing outgrants and to provide auditing information for program with financial involvement.

EFFECTS OF NONDISCLOSURE

Disclosure of information is voluntary. Failure to provide information will preclude issuance of the permit/license/consent to easement.

Special Note from the Operations Manager:

Thank you for the submission of a completed shoreline application. Normal processing time of an application varies depending on the facility and activity but is generally three to five weeks. Please contact the Park Ranger that supplied the application for a status or to answer any questions. Remember, that no modifications may be completed without prior approval from the Corps of Engineers and that your Permit/License/Consent to Easement will expire in five years and must be renewed prior to the expiration date. As always, please be safe while recreating or working around the water and always wear your life jacket while boating.

SECTION A

FOR AGENCY USE ONLY

ACOE Application #
Date Application Received
Proposed Project Lat.
Proposed Project Long.

DEP/WMD Application #
Date Application Received
Fee Received \$
Fee Receipt #

PART 1:

Are any of the activities described in this application proposed to occur in, on, or over wetlands or other surface waters?

Yes No

Is this application being filed by or on behalf of a government entity or drainage district? Yes No

- A. Type of Environmental Resource Permit Requested (check at least one). See Attachment 2 for thresholds and descriptions.
- Noticed General - include information requested in Section B.
 - Standard General (Single Family Dwelling) - include information requested in Sections C and D.
 - Standard General (all other Standard General projects) - include information requested in Sections C and E.
 - Individual (Single Family Dwelling) - include information requested in Sections C and D.
 - Individual (all other Individual projects) - include information requested in Sections C and E.
 - Conceptual - include information requested in Sections C and E.
 - Mitigation Bank Permit (construction) - include information requested in Sections C and F. (If the proposed mitigation bank involves the construction of a surface water management system requiring another permit defined above, check the appropriate box and submit the information requested by the applicable section.)
 - Mitigation Bank (conceptual) - include information requested in Sections C and F.
- B. Type of activity for which you are applying (check at least one)
- Construction or operation of a new system, other than a solid waste facility, including dredging or filling in, on or over wetlands and other surface waters.
 - Construction, expansion or modification of a solid waste facility.
 - Alteration or operation of an existing system which was not previously permitted by a WMD or DEP.
 - Modification of a system previously permitted by a WMD or DEP.
Provide previous permit numbers: _____
 - Alteration of a system Extension of permit duration
 - Abandonment of a system Construction of additional phases of a system
 - Removal of a system
- C. Are you requesting authorization to use Sovereign Submerged Lands?
Yes No
(See Section G and Attachment 5 for more information before answering this question.)
- D. For activities in, on, or over wetlands or other surface waters, check type of federal dredge and fill permit requested:
- | | | |
|-------------------------------------|---|----------------------------------|
| <input type="checkbox"/> Individual | <input type="checkbox"/> Programmatic General | <input type="checkbox"/> General |
| <input type="checkbox"/> Nationwide | <input type="checkbox"/> Not Applicable | |
- E. Are you claiming to qualify for an exemption? Yes No
If yes, provide rule number if known. ____

PART 3: A. OWNER(S) OF LAND

Name

Title and Company

Address

City, State, Zip

Telephone and Fax

B. ENTITY TO RECEIVE PERMIT (IF OTHER THAN OWNER)

Name

Title and Company

Address

City, State, Zip

Telephone and Fax

C. AGENT AUTHORIZED TO SECURE PERMIT

Name

Title and Company

Address

City, State, Zip

Telephone and Fax

D. CONSULTANT (IF DIFFERENT FROM AGENT)

Name

Title and Company

Address

City, State, Zip

Telephone and Fax

PART 4: (Please provide metric equivalent for federally funded projects):

- A. Name of Project, including phase if applicable:
- B. Is this application for part of a multi-phase project?
Yes No
- C. Total applicant-owned area contiguous to the project?
___ ac.; ___ ha.
- D. Total area served by the system: ___ ac.; ___ ha.
- E. Impervious area for which a permit is sought: ___ ac.; ___ ha.
- F. Volume of water that the system is capable of impounding:
___ ac. ft.; ___ m
- G. What is the total area of work in, on, or over wetlands or other surface waters?
___ ac.; ___ ha. ___ sq. ft.; ___ sq. m.
- H. Total volume of material to be dredged: ___ yd; ___ m
- I. Number of new boat slips proposed: ___ wet slips; ___ dry slips

PART 5:

Project location (use additional sheets if needed):

County(ies)___		
Section(s)	Township	Range
Section(s)	Township	Range
Section(s)	Township	Range

Land Grant name, if applicable:

Tax Parcel Identification Number:

Street Address/Road or other location:

City, Zip Code, if applicable:

PART 6: Describe in general terms the proposed project, system, or activity.

PART 7:

A. If there have been any pre-application meetings, including on-site meetings, with regulatory staff, please list the date(s), location(s), and names of key staff and project representatives.

B. Please identify by number any MSSW/Wetland Resource/ERP/ACOE Permits pending, issued or denied for projects at the location, and any related enforcement actions.

Agency	Date	No.\Type of Application	Action Taken
_____	_____	_____	_____
_____	_____	_____	_____
_____	_____	_____	_____

C. Note: The following information is required for projects proposed to occur in, on or over wetlands that need a federal dredge and fill permit or an authorization to use state owned submerged lands. Please provide the names, addresses and zip codes of property owners whose property directly adjoin the project (excluding application) and/or (for proprietary authorizations) is located within a 500 ft. radius of the applicant's land. Please attach a plan view showing the owner's names and adjoining property lines. Attach additional sheets if necessary.

- | | |
|----|----|
| 1. | 2. |
| 3. | 4. |
| 5. | 6. |
| 7. | 8. |

PART 8:

A. By signing this application form, I am applying, or I am applying on behalf of the applicant, for the permit and any proprietary authorizations identified above, according to the supporting data and other incidental information filed with this application. I am familiar with the information contained in this application and represent that such information is true, complete and accurate. I understand this is an application and not a permit, and that work prior to approval is a violation. I understand that this application and any permit issued or proprietary authorization issued pursuant thereto, does not relive me of any obligation for obtaining any other required federal, state, water management district or local permit prior to commencement of construction. I agree, or I agree on behalf of the applicant, to operate and maintain the permitted system unless the permitting agency authorizes transfer of the permit to a responsible operation entity. I understand that knowingly making any false statement or representation in this application is a violation of Section 373.430, F.S. and 18 U.S.C. Section 1001.

Typed/Printed Name of Applicant (If no Agent is used) or Agent (If one is so authorized below)

Signature of Applicant/Agent

Date

(Corporate Title if applicable)

AN AGENT MAY SIGN ABOVE ONLY IF THE APPLICANT COMPLETES THE FOLLOWING:

B. I hereby designate and authorize the agent listed above to act on my behalf, or on behalf of my corporation, as the agent in the processing of this application for the permit and/or proprietary authorization indicated above; and to furnish, on request, supplemental information in support of the application. In addition, I authorize the above-listed agent to bind me, or my corporation, to perform any requirements which may be necessary to procure the permit or authorization indicated above. I understand that knowingly making any false statement or representation in this application is a violation of Section 373.430, F.S. and 18 U.S.C. Section 1001.

Typed/Printed Name of Applicant

Signature of Applicant

Date

(Corporate Title if applicable)

Please note: The applicant's original signature (not a copy) is required above.

PERSON AUTHORIZING ACCESS TO THE PROPERTY MUST COMPLETE THE FOLLOWING:

C. I either own the property described in this application or I have legal authority to allow access to the property, and I consent, after receiving prior notification, to any site visit on the property by agents or personnel from the Department of Environmental Protection, the Water Management District and the U.S. Army Corps of Engineers necessary for the review and inspection of the proposed project specified in this application. I authorize these agents or personnel to enter the property as many times as may be necessary to make such review and inspection. Further, I agree to provide entry to the project site for such agents or personnel to monitor permitted work if a permit is granted.

Typed/Printed Name of Applicant

Signature of Applicant

Date

(Corporate Title if applicable)